

NEON

OWNER'S MANUAL

REF. NEOLB7050



9.8 *Fluoar*

REF. NEOLB7080



10.4 *Blank*

REF. NEOLB7100 / NEOLB7150



10.8 *Led*

REF. NEOLB7350



11.0 *Switch*

REF. NEOLB7400



12.0 *Volt*

REF. NEOLB7430



12.6 *Flash*

NEON-SUP.COM

OBSERVE THE FOLLOWING SAFETY PRECAUTIONS WHENEVER USING THE PRODUCT

SAFETY INSTRUCTIONS:

OBSERVE THE FOLLOWING SAFETY PRECAUTIONS WHENEVER USING THE PRODUCT.

1. WARNING

STAND-UP PADDLE IS A POTENTIALLY DANGEROUS SPORT AND MAY BE PHYSICALLY DIFFICULT FOR SOME PEOPLE.

FAILURE TO COMPLY WITH SAFETY STANDARDS, IMPROPER USE OF THE BOARD AND FAILURE TO OBSERVE THE RECOMMENDATIONS FOR USE CAN LEAD TO SERIOUS OR IRREVERSIBLE INJURY, OR EVEN DEATH.

FOR ANY QUESTIONS CONCERNING THIS PRODUCT, PLEASE DO NOT HESITATE TO CONTACT US ON +33 (0)4 92 79 77 03 OR BY E-MAIL AT HELLO@NEON-SUP.COM



THE MAXIMUM PRESSURE IS 15 PSI (1.0 BAR). HOWEVER WE ADVISE YOU TO INFLATE YOUR SUP TO 13 PSI (0.9 Bar) TO KEEP A 3 PSI SAFETY MARGIN FOR WHEN PRESSURE INCREASES DUE TO EXPOSURE IN STRONG SUN.

2. RECOMMENDATIONS - GENERAL ADVICE

- DO NOT OVERESTIMATE YOUR PHYSICAL AND TECHNICAL CAPABILITIES.
- CHECK THE CONDITION OF YOUR EQUIPMENT BEFORE EACH USE.
- IF IN DOUBT, CONSULT YOUR DOCTOR BEFORE STARTING STAND UP PADDLING.
- ASSESS POSSIBLE DANGERS BEFORE ENTERING THE WATER. MAKE SURE YOU ARE AWARE OF THE PARTICULAR CONDITIONS OF THE AREA OF WATER YOU HAVE CHOSEN TO GO INTO.
- ALWAYS CONSULT THE REGULATIONS CONCERNING ACCESS, MOVEMENT AND CIRCULATION ON THE SITE YOU HAVE CHOSEN, AS WELL AS THE METEOROLOGICAL CONDITIONS AND THE STATE OF THE SEA (TIDES, CURRENTS, POLLUTION, PROTECTED ZONES) OR THE STATE OF OTHER BODY OF WATER (FLOODS, POLLUTION, PROTECTED AREAS).
- ALWAYS BE AWARE OF AND RESPECT THE OTHER USERS OF THE AQUATIC ENVIRONMENT (SURFERS, SWIMMERS, SAILORS, FISHERMEN...).
- IN FRANCE, YOU MUST NOT BE FURTHER THAN 300M FROM THE SHORE BECAUSE AN INFLATABLE STAND UP PADDLE IS CONSIDERED TO BE A BEACH TOY. LEARN ABOUT CURRENT REGULATIONS IF YOU ARE IN ANOTHER COUNTRY.
- DO NOT USE THE STAND UP PADDLE IN AN OFFSHORE WIND OR A WIND ABOVE 11 KNOTS (20 KM/H). THIS ADVICE BECOMES OBLIGATORY IF THERE IS AN OFFSHORE WIND.
- WEARING AN APPROVED BUOYANCY AID OR NEOPRENE SUIT HELPS WITH BUOYANCY AND IS HIGHLY RECOMMENDED AND MAY BE MANDATORY IN SOME LOCATIONS. CONSULT LOCAL REGULATIONS.
- ADAPT WHAT YOU WEAR AND ANTICIPATE CHANGES IN THE WEATHER BY CONSULTING THE WEATHER FORECAST AND CHECKING IT REGULARLY FOR CHANGES THROUGHOUT THE DAY SO AS NOT TO BE SURPRISED BY WIND OR COLD.
- NEVER PADDLE ALONE. ALWAYS TELL SOMEONE WHEN YOU ARE GOING OUT AND HOW LONG YOU WILL BE.
- A STAND UP PADDLE SHOULD NEVER BE USED BY AN UNATTENDED OR UNACCOMPANIED CHILD.
- IN WHITE WATER, THE USE OF THE LEASH IS STRONGLY DISCOURAGED. AT SEA, OR ON OTHER BODIES OF WATER, THE LEASH IS ESSENTIAL.
- DO NOT CONSUME OR BE UNDER THE INFLUENCE OF ALCOHOL OR DRUGS BEFORE AND DURING THE USE OF A STAND UP PADDLE.
- DO NOT USE A STAND UP PADDLE IN FLOOD CONDITIONS.

USE:

1. INFLATION AND MOUNTING

ABSOLUTELY DO NOT USE A HIGH-PRESSURE COMPRESSOR. IF THE BOARD IS OVER PRESSURISED IT WILL SUFFER IRREPARABLE, UNGUARANTEED, DAMAGE AND COULD INJURE THE USER.

- 1 - UNROLL THE SUP ON A FLAT, CLEAN SURFACE.
- 2 - UNSCREW THE VALVE CAP (B).
- 3 - RAISE THE CENTRE KNOB IN THE VALVE BY TURNING IT 1/4 OF A TURN COUNTER CLOCKWISE (A). IT POPS UP IN A HIGH POSITION.
- 4 - INSERT THE TUBE OF THE HAND PUMP. THE TIP FITS A 1/4 TURN INTO THE VALVE. 5 - THEN INFLATE YOUR SUP.
- 6 - TURN THE BOARD OVER AND SLIDE THE CENTRAL FIN INTO THE SLIDE UNTIL IT STOPS.
- 7 - INSERT THE LOCKING TAB. THE FIN IS MOUNTED.

DO NOT SUBJECT THE SUP TO PROLONGED SUN EXPOSURE THAT COULD INCREASE THE PRESSURE OF YOUR SUP BEYOND 18 PSI. DO NOT HOLD YOUR FACE TOO CLOSE TO THE VALVE WHEN INFLATING AND DEFLATING. THE VALVE MAY BE DAMAGED AND SAND OR OTHER DEBRIS MAY BE EJECTED.

IN CASE OF OVEREXPOSURE TO THE SUN, REGULARLY LOWER THE PRESSURE OF YOUR SUP BY DEFLATING IT.

2. CLEANING, DEFLATION AND STORAGE

- 1 - PLACE THE SUP ON A CLEAN, FLAT SURFACE.
- 2 - RINSE WITH CLEAN WATER AFTER EACH USE AT SEA.
- 3 - TAKE OUT THE FIN.
- 4 - UNSCREW THE VALVE CAP (B).
- 5 - PRESS ON THE CENTRE BUTTON IN THE VALVE (A) AND TURN 1/4 OF A TURN CLOCKWISE UNTIL IT LOCKS.
- 6 - THE AIR ESCAPES AUTOMATICALLY AND THE BUTTON IS AT THE BOTTOM.
- 7 - IF YOU WISH TO STOP DEFLATION, PRESS THE BUTTON AND TURN IT 1/4 OF A TURN COUNTER CLOCKWISE. DEFLATION WILL STOP WHEN THE BUTTON RISES.
- 8 - DRY WITH A TOWEL OR A SOFT CLOTH TO PREVENT ANY (B) MOULD FORMING OR DETERIORATION OF THE FABRIC AND THEN ROLL THE BOARD STARTING FROM THE OPPOSITE END TO THE VALVE. THE AIR WILL CONTINUE TO ESCAPE THROUGH THE VALVE.
- 9 - CLOSE THE CAP (B) OF THE VALVE.
- 10 - FOLD THE BOARD WITH THE FINNS FACING OUTWARDS TO ENSURE THE EVA PAD LONGEVITY.
- 11 - STORE THE BOARD IN A DRY PLACE.

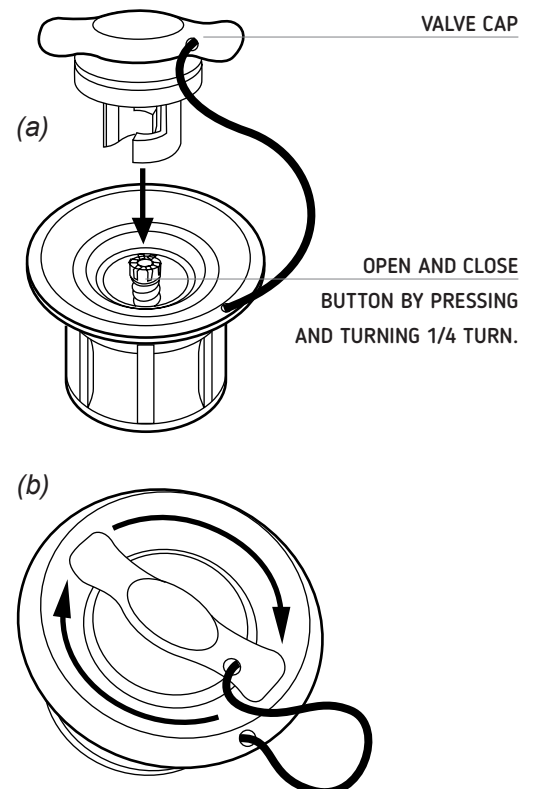

WARRANTY :

ALL OUR SUPS ARE GUARANTEED FOR 2 YEARS AGAINST CONSTRUCTION DEFECTS.